

**1****TYPE**

- Type **A**: with pull ring, without rest position.
- Type **C**: with pull ring, with rest position.
- Type **E**: with pull lever, with stop position.

**2****3****Guide**

Steel precision casting:

zinc-plated, blue passivated **ZB****4**

zinc-plated and coated in epoxy resin:

black, RAL 9005, matte finish **SW****5****Lever**

Steel precision casting:

zinc-plated, blue passivated

**6****Plunger pin / Pull ring**

Zinc-plated steel, blue passivated

**7****Spring**

AISI 316Ti stainless Steel

**8****Grub screw**

Steel, zinc-plated

**9****FEATURES AND APPLICATIONS**

In the GN 722.6 spring indexing plungers the plunger pin is actuated by the pull ring or lever. This operation is performed manually, with a cable or by means of a pulling hook in the versions with pull ring. The dimensional tolerances between the tip and the guide body are chosen in order to guarantee functional reliability even in applications of approximate dimensions or in the event of contamination. For fastening, slotted or hexagonal mounting holes allow the use of socket cap screws and hexagon screws or nuts.

**10****11****12****13****14****15****16****17****18****19**

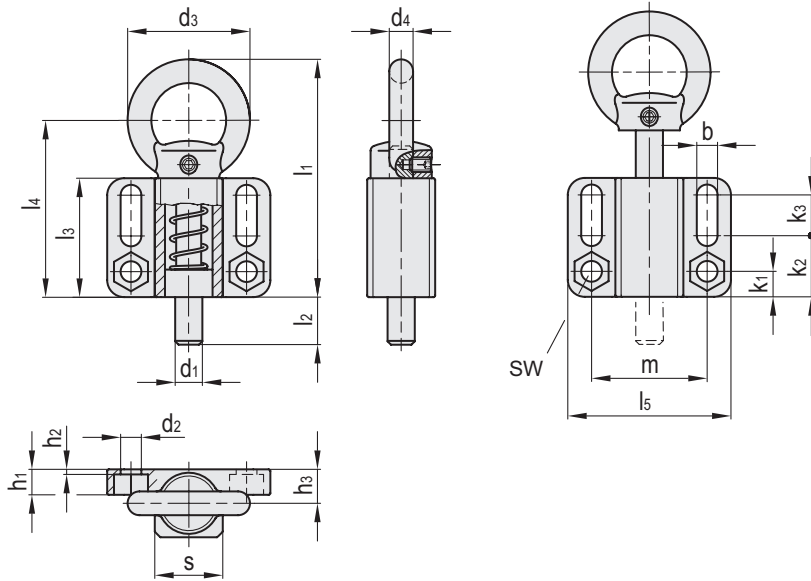

Conversion Table 1 mm = 0.039 inch	
d1	
mm	inch
8	0.31
10	0.39
12	0.47
14	0.55
16	0.62
20	0.78

GN 722.6-A-ZB

METRIC

Code	Description	d1		d3	d4	b+0.3	h1	h2	h3	k1	k2	k3	l1	l2	l3	l4	l5	s	sw	m	Spring	Spring	Δ	
		Plunger	Hole																		preload	max load		
GN.29033	GN 722.6-8-20-A-ZB	8	-0.05 +0.1	6.1	36	7	6.1	7.5	1.5	10	7.5	18	12	70	14	35	52	48	20	10	34	14	35	180
GN.29036	GN 722.6-10-20-A-ZB	10	-0.25 +0.3	6.1	36	7	6.1	7.5	1.5	10	7.5	18	12	70	14	35	52	48	20	10	34	14	35	187
GN.29039	GN 722.6-12-20-A-ZB	12	-0.05 +0.3	6.1	36	7	6.1	7.5	1.5	10	7.5	18	12	70	14	35	52	48	20	10	34	14	35	188
GN.29042	GN 722.6-14-20-A-ZB	14	-0.05 +0.3	6.1	36	7	6.1	7.5	1.5	10	7.5	18	12	70	14	35	52	48	20	10	34	14	35	191
GN.29045	GN 722.6-16-30-A-ZB	16	-0.05 +0.3	10.1	50	10	10.1	15	5	15	14	34	10	103	20	54	78	80	30	17	55	22	70	803
GN.29048	GN 722.6-20-30-A-ZB	20	-0.05 +0.3	10.1	50	10	10.1	15	5	15	14	34	10	103	20	54	78	80	30	17	55	22	70	821

GN 722.6-A-SW

Code	Description	d1		d3	d4	b+0.3	h1	h2	h3	k1	k2	k3	l1	l2	l3	l4	l5	s	sw	m	Spring	Spring	Δ	
		Plunger	Hole																		preload	max load		
GN.29032	GN 722.6-8-20-A-SW	8	-0.05 +0.3	6.1	36	7	6.1	7.5	1.5	10	7.5	18	12	70	14	35	52	48	20	10	34	14	35	180
GN.29035	GN 722.6-10-20-A-SW	10	-0.05 +0.3	6.1	36	7	6.1	7.5	1.5	10	7.5	18	12	70	14	35	52	48	20	10	34	14	35	187
GN.29038	GN 722.6-12-20-A-SW	12	-0.05 +0.3	6.1	36	7	6.1	7.5	1.5	10	7.5	18	12	70	14	35	52	48	20	10	34	14	35	188
GN.29041	GN 722.6-14-20-A-SW	14	-0.05 +0.3	6.1	36	7	6.1	7.5	1.5	10	7.5	18	12	70	14	35	52	48	20	10	34	14	35	191
GN.29044	GN 722.6-16-30-A-SW	16	-0.05 +0.3	10.1	50	10	10.1	15	5	15	14	34	10	103	20	54	78	80	30	17	55	22	70	803
GN.29047	GN 722.6-20-30-A-SW	20	-0.05 +0.3	10.1	50	10	10.1	15	5	15	14	34	10	103	20	54	78	80	30	17	55	22	70	821



Indexing and positioning elements

- 1
- 2
- 3
- 4
- 5
- 6
- 7
- 8
- 9
- 10
- 11
- 12
- 13
- 14
- 15
- 16
- 17
- 18
- 19

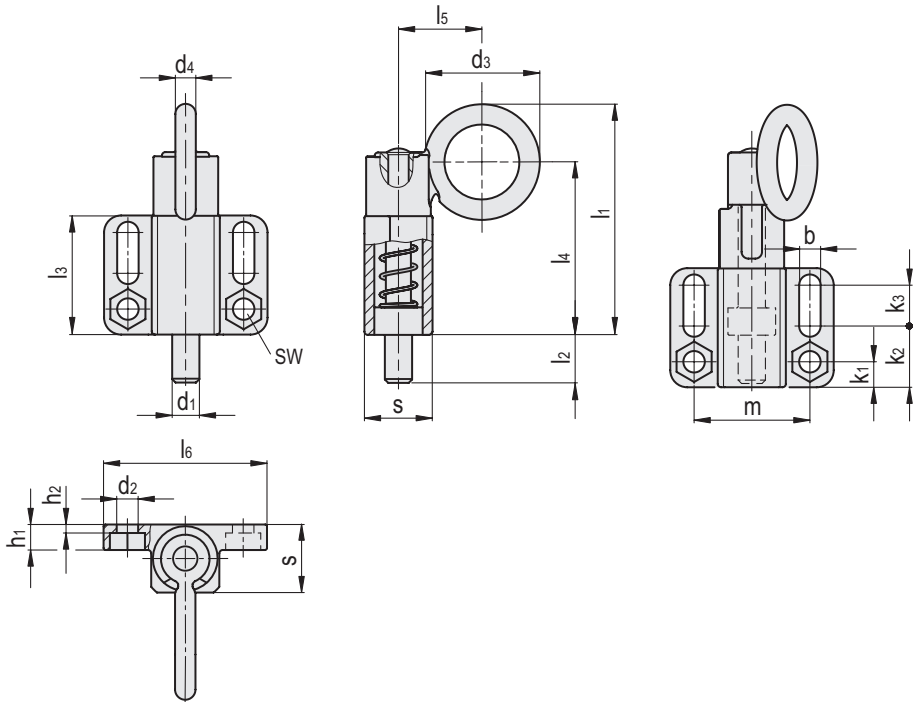

Conversion Table	
1 mm = 0.039 inch	
d1	
mm	inch
8	0.31
10	0.39
12	0.47
14	0.55
16	0.62
20	0.78

METRIC

GN 722.6-C-ZB

Code	Description	d1		d2	d3	d4	b+0.3	h1	h2	k1	k2	k3	l1	l2	l3	l4	l5	l6	s	sw	m	Spring		
		Plunger	Hole																			preload [N]	max load [N]	
GN.49553	GN 722.6-8-20-C-ZB	8	-0.05	6.1	34	6	6.1	7.5	1.5	7.5	18	12	68	14	35	51	41.5	48	20	10	34	14	35	180
GN.49556	GN 722.6-10-20-C-ZB	10	-0.25	6.1	34	6	6.1	7.5	1.5	7.5	18	12	68	14	35	51	41.5	48	20	10	34	14	35	182
GN.49559	GN 722.6-12-20-C-ZB	12	-0.25	6.1	34	6	6.1	7.5	1.5	7.5	18	12	68	14	35	51	41.5	48	20	10	34	14	35	184
GN.49562	GN 722.6-14-20-C-ZB	14	-0.25	6.1	34	6	6.1	7.5	1.5	7.5	18	12	68	14	35	51	41.5	48	20	10	34	14	35	186
GN.49565	GN 722.6-16-30-C-ZB	16	+0.3	10.1	48	9	10.1	15	5	14	34	10	102	20	54	78	60	80	30	17	55	22	70	755
GN.49568	GN 722.6-20-30-C-ZB	20	+0.3	10.1	48	9	10.1	15	5	14	34	10	102	20	54	78	60	80	30	17	55	22	70	765

GN 722.6-C-SW

Code	Description	d1		d2	d3	d4	b+0.3	h1	h2	k1	k2	k3	l1	l2	l3	l4	l5	l6	s	sw	m	Spring		
		Plunger	Hole																			preload [N]	max load [N]	
GN.49552	GN 722.6-8-20-C-SW	8	-0.05	6.1	34	6	6.1	7.5	1.5	7.5	18	12	68	14	35	51	41.5	48	20	10	34	14	35	180
GN.49555	GN 722.6-10-20-C-SW	10	-0.25	6.1	34	6	6.1	7.5	1.5	7.5	18	12	68	14	35	51	41.5	48	20	10	34	14	35	182
GN.49558	GN 722.6-12-20-C-SW	12	-0.25	6.1	34	6	6.1	7.5	1.5	7.5	18	12	68	14	35	51	41.5	48	20	10	34	14	35	184
GN.49561	GN 722.6-14-20-C-SW	14	-0.25	6.1	34	6	6.1	7.5	1.5	7.5	18	12	68	14	35	51	41.5	48	20	10	34	14	35	186
GN.49564	GN 722.6-16-30-C-SW	16	+0.3	10.1	48	9	10.1	15	5	14	34	10	102	20	54	78	60	80	30	17	55	22	70	755
GN.49567	GN 722.6-20-30-C-SW	20	+0.3	10.1	48	9	10.1	15	5	14	34	10	102	20	54	78	60	80	30	17	55	22	70	765

Indexing and positioning elements

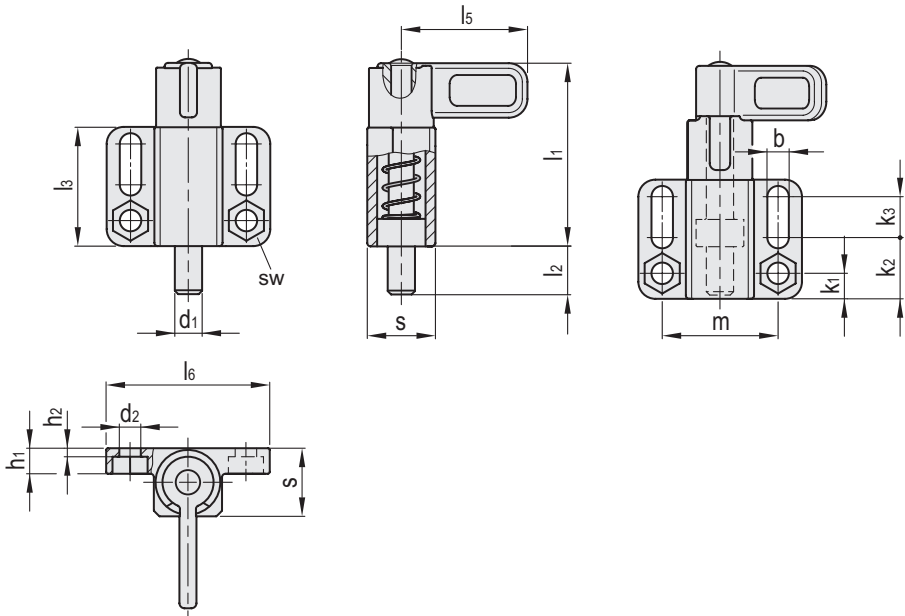

Conversion Table 1 mm = 0.039 inch	
d1	
mm	inch
8	0.31
10	0.39
12	0.47
14	0.55
16	0.62
20	0.78

GN 722.6-E-ZB

METRIC

Code	Description	d1		d2	b+0.3	h1	h2	k1	k2	k3	l1	l2	l3	l5	l6	s	sw	m	Spring preload [N]	Spring max load [N]	△
		Plunger -0.05	-0.25 Hole +0.1 +0.3																		
GN.75881	GN 722.6-8-20-E-ZB	8		6.1	6.1	7.5	1.5	7.5	18	12	54	14	35	37	48	20	10	34	14	35	179
GN.75884	GN 722.6-10-20-E-ZB	10		6.1	6.1	7.5	1.5	7.5	18	12	54	14	35	37	48	20	10	34	14	35	182
GN.75887	GN 722.6-12-20-E-ZB	12		6.1	6.1	7.5	1.5	7.5	18	12	54	14	35	37	48	20	10	34	14	35	186
GN.75890	GN 722.6-14-20-E-ZB	14		6.1	6.1	7.5	1.5	7.5	18	12	54	14	35	37	48	20	10	34	14	35	191
GN.75893	GN 722.6-16-30-E-ZB	16		10.1	10.1	15	5	14	34	10	83	20	54	55	80	30	17	55	22	70	755
GN.75896	GN 722.6-20-30-E-ZB	20		10.1	10.1	15	5	14	34	10	83	20	54	55	80	30	17	55	22	70	772

GN 722.6-E-SW

Code	Description	d1		d2	b+0.3	h1	h2	k1	k2	k3	l1	l2	l3	l5	l6	s	sw	m	Spring preload [N]	Spring max load [N]	△
		Plunger -0.05	-0.25 Hole +0.1 +0.3																		
GN.75880	GN 722.6-8-20-E-SW	8		6.1	6.1	7.5	1.5	7.5	18	12	54	14	35	37	48	20	10	34	14	35	179
GN.75883	GN 722.6-10-20-E-SW	10		6.1	6.1	7.5	1.5	7.5	18	12	54	14	35	37	48	20	10	34	14	35	182
GN.75886	GN 722.6-12-20-E-SW	12		6.1	6.1	7.5	1.5	7.5	18	12	54	14	35	37	48	20	10	34	14	35	186
GN.75889	GN 722.6-14-20-E-SW	14		6.1	6.1	7.5	1.5	7.5	18	12	54	14	35	37	48	20	10	34	14	35	191
GN.75892	GN 722.6-16-30-E-SW	16		10.1	10.1	15	5	14	34	10	83	20	54	55	80	30	17	55	22	70	755
GN.75895	GN 722.6-20-30-E-SW	20		10.1	10.1	15	5	14	34	10	83	20	54	55	80	30	17	55	22	70	772

Indexing and positioning elements